

# Stormtite™ AP Door System

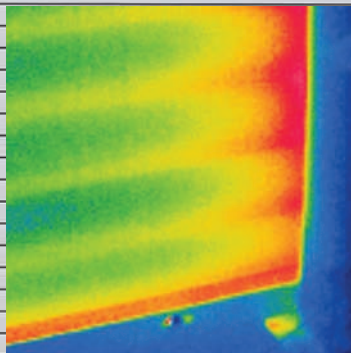

STANDARD DOOR

STORMTITE™ AP DOOR

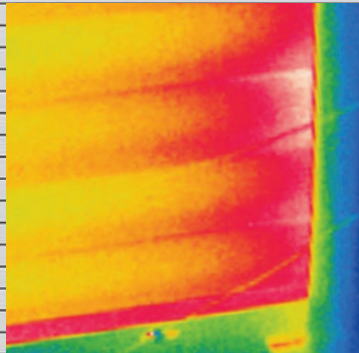
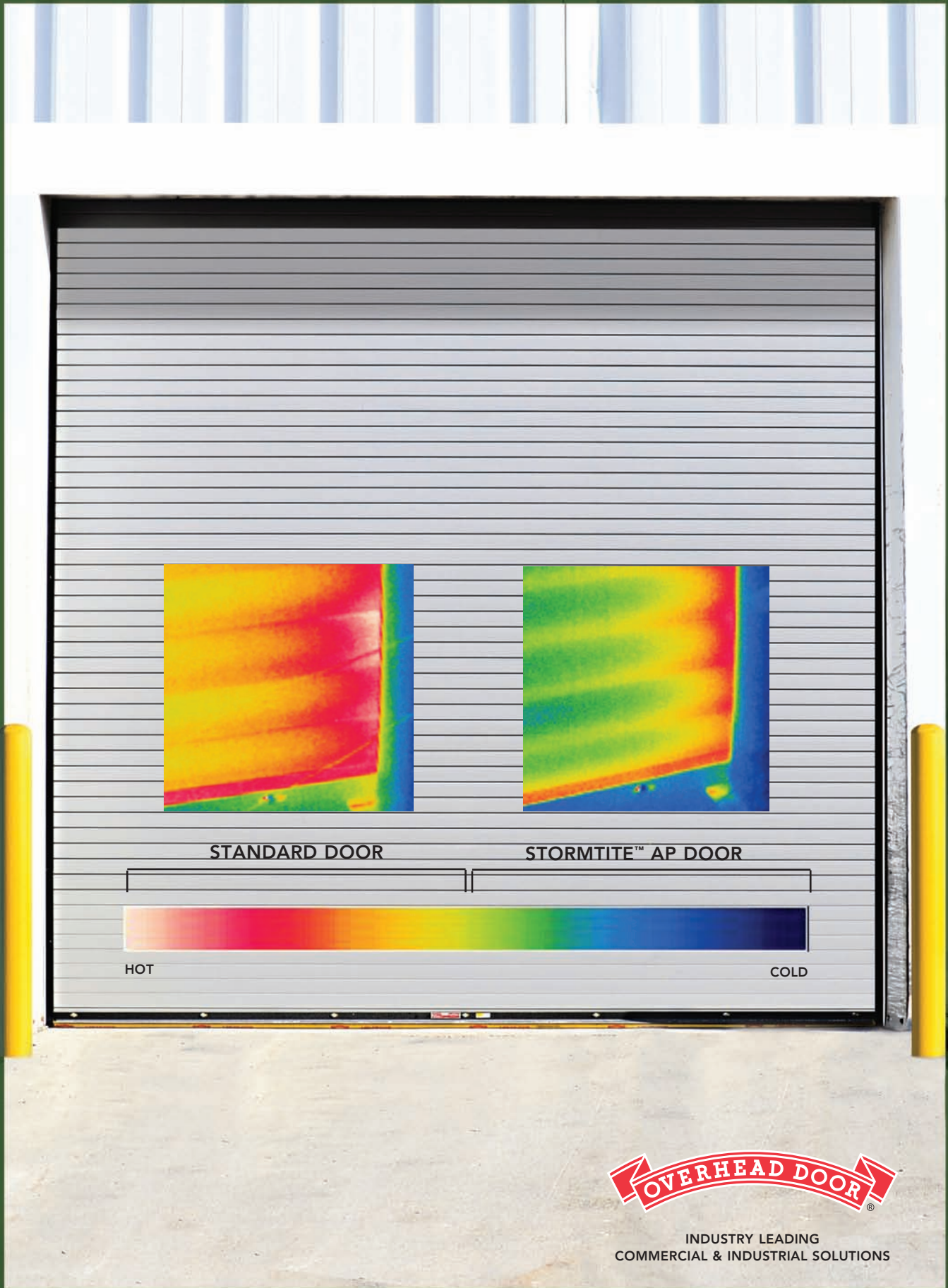

HOT

COLD

MODEL

627



INDUSTRY LEADING  
COMMERCIAL & INDUSTRIAL SOLUTIONS

# Stormtite™ AP Advanced Performance Insulated Rolling Doors

## MODEL 627

### Standard Features At a Glance

Max. standard width	30' (9144 mm)
Max. standard height	19' (8534 mm)
Curtain	24 gauge galvanized steel front 24 gauge galvanized steel back
Slat profile	Flat, insulated, type FIT-265
Insulation	Foamed-in-place, CFC and HCFC-free polyurethane
R-value*	10.9 (1.91 W/Msq)
U-factor†	0.84
STC Rating	Through Curtain 28; Installed System; 21
Flame Spread and Smoke Index	Class A or 1
Finish	Gray, tan, brown or white
Hood	24 ga. galvanized steel
Wind load	20 psf
Standard mounting	Face of wall
Operation	Chain hoist
Standard springs	20,000 cycle
Advanced Perimeter Protection	Bottom weatherseal, interior and exterior EPDM triple-finned guide brush weatherseals, interior hood baffle, and lintel seal
Guides	3-angle structural steel; black powder coated
Bottom bar	Black powder coated steel with vinyl weatherseal
Lock	Chain keeper
Warranty	24-month limited on door or 3 year limited on door and operator system

### Options

- Between-jamb mounting
- Electric (RHX®, RSX®, RMX®) or crank operation
- Bottom sensing edge
- Sloping bottom bar
- Stainless steel (22 gauge front/24 gauge back)  
or aluminum slats
- PowderGuard™ Zinc or Weathered finishes available on curtain,  
steel bottom bar angles and guides
- PowderGuard™ Premium powder coat paint finish in 197  
standard colors, or color-matched to specification
- Insulated vision lites uniformly spaced of 1" x 10"  
(25.4 mm x 254 mm)
- High cycle counter balance with high usage package
- High-wind load option
- Cylinder lock
- Special application doors:
  - Oversized doors
  - Combination doors (2 doors on a single head plate)
  - Pass doors

\* R-value is a measure of thermal efficiency. The higher the R-value the greater the insulating properties of the door. Overhead Door Corporation uses a calculated door curtain R-value for our insulated doors.

## Stormtite™ AP delivers advanced

The Stormtite™ AP Model 627 is engineered to supply advanced performance in industrial and general commercial applications where thermal performance, climate control and security are primary concerns.

### The Solution for Demanding Application Needs

Backed by an industry leading 3 year door and operator system warranty, the Stormtite™ AP door system's advanced performance answers the demand for more reliability, durability, security, flexibility and thermal efficiency. Ideal applications include the following:

- Industrial manufacturing facilities
- Government facilities
- Public facilities
- Food and beverage distribution facilities
- Climate controlled facilities
- Healthcare facilities
- Shipping and receiving docks

### Advanced Performance in an Insulated Rolling Door System

This door system presents the most advanced thermal performance values published by any major US manufacturer of insulated rolling steel doors, with an R-value\* of 10.9, U-value\*\* of 0.09 and a tested installed U-factor† of 0.84. When compared to the International Energy Conservation Code (IECC) 2012 requirements, the Stormtite™ AP Model 627 far surpasses these. The superior construction of this rolling service door and the advanced design of the perimeter seals offer superior door protection against air leakage. The innovative EPDM triple-finned guide brush weatherseals (located on interior and exterior of guide), work in tandem with the hood baffle and bottom bar weather seals to reduce air leakage through the entire door system perimeter.

The sound performance of the Stormtite™ AP Model 627 furnishes a through curtain Sound Transmission Class (STC) rating of 28 and installed system rating of 21. The higher the STC rating the better the buffering is from the transmission of sound through and around the door. This insulated door system also includes a flame spread and smoke index of class A or 1, the highest rating possible and complies with National Fire Protection Association (NFPA), Underwriters Laboratories (UL) and International Building Code (IBC) requirements.

### Stormtite™ Secures Against Elements and Forced Entry

The Stormtite™ AP Model 627 is constructed of interlocking slats with endlocks and/or windlocks. This design supplies

\*\* U-value is a measure of the flow of heat through an insulating or building material: the lower the U-value, the better the insulating ability. U-value is the inverse of R-value.



thermal performance, climate control and security.



Stormtite™ AP Model 627 insulated rolling service door installed at a manufacturing plant in Lewistown, Pennsylvania.

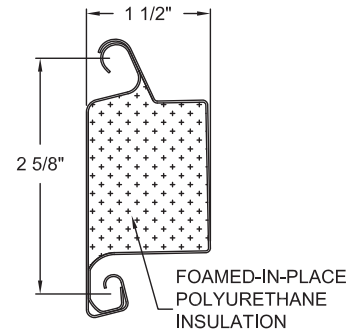

This uniquely designed rolling door slat measuring 1.4" in thickness, provides advanced thermal performance and increased durability.



This innovative triple-finned EPDM brush seal protects the interior and exterior perimeter of the door system against the elements.

resistance against forced exterior entry and several interior lock options can supply additional security. The 627 delivers 20 psf (design pressure) wind load protection, which is equivalent to approximately 90 to 110 mph wind speed (comparable to hurricane force wind category 1 to 2). This model can be built to accommodate higher wind loading upon request.

#### Flexibility in Operation

This Stormtite™ AP door system comes with chain hoist operation standard; crank and motor operation options are also available. The varied options of operation and mounting (left or right handed) afford flexibility to meet the needs of the facility and application.

#### Many Options, Customized Solutions

The Stormtite™ AP Model 627 is available with a number of options to meet individual application needs. The large insulated vision lite features thick dual-wall polycarbonate which affords advanced

insulation properties as well as maximum visibility and light transmittance. Slat options include a choice of steel (standard), stainless steel or aluminum. Finish options include a choice of 4 standard colors as well as the PowderGuard™ Zinc Premium powder coat finish in 197 standard colors or color-matched to specification. The PowderGuard™ Zinc and PowderGuard™ Weathered finishes are also available for the door curtain as well as bottom bar angles and guides.

Special application options include oversized doors, combination doors (2 doors on a single head plate), and pass doors. Ask your Overhead Door Distributor for more information about the special applications options.

For additional information, or special project requirements, consult your Overhead Door Distributor or the Overhead Door Architectural Design Manual.

† Installed U-Factor - A tested value of actual energy loss - whether heat or cold - of an installed door, wall, or window assembly. The lower the number the lower the energy loss and therefore the better the thermal performance. U-factor will vary between 0.66 and 1.00 depending on finish and color selection. For best U-factor, choose finish and color with high solar reflectance (bright colors).

---

## The Original, Innovative Choice for Unequaled Quality and Service

---

Overhead Door Corporation pioneered the upward-acting door industry, inventing the first upward-acting door in 1921 and the first electric door operator in 1926. Today, we continue to be the industry leader through the strength of our product innovation, superior craftsmanship and outstanding customer support, underscoring a legacy of quality, expertise and integrity. That's why design and construction professionals specify Overhead Door Corporation products more often than any other brand.

The Overhead Door Red Ribbon is a mark of quality that also reflects the pride we take in the people who support our products. Our family of over 400 Overhead Door Distributors across the country not only share our name and logo, but also our commitment to excellence. Your Overhead Door Distributor will work with you in a consultative role to ensure that product selections achieve your design and application requirements — in addition to offering expert installation, professional field service and ongoing maintenance. From project design and manufacturing to installation and service, the Overhead Door Red Ribbon is your guarantee of genuine quality and turnkey service excellence.

- **Together with our distributors, we offer comprehensive technical information and resource materials to support your project, including:**
- Architectural Design Manual – a comprehensive guide to selecting, specifying and detailing all commercial and industrial Overhead Door products can be found at [www.OverheadDoor.com/ADM/base.html](http://www.OverheadDoor.com/ADM/base.html)
- Operation & Maintenance Manual – detailed product information, customized for your project, to ensure reliable, long-life door system operation
- Custom application and technical assistance through ordering plants' customer service and technical services respectively
- Visit our Architect's Corner at [www.OverheadDoor.com](http://www.OverheadDoor.com)



Advanced Rolling Steel Door  
RapidSlat™



Thermacore™ Sectional Doors



Rolling & Side Folding  
Security Grilles & Closures



Rolling Service Doors



Commercial Operators

Today, Overhead Door Corporation – along with our Horton Automatics division, for automated pedestrian entrances – is recognized as the leading, single-source manufacturer of integrated door and operator systems for commercial, industrial and residential applications. With multiple manufacturing locations throughout the United States, a state-of-the-art TREQ (Testing, Reliability, Engineering, and Quality) Center for design and engineering, and a national network of authorized Overhead Door Distributors, our capabilities are leading-edge and our field service and technical support second to none. Built best and backed best, Overhead Door is the industry's leading choice for quality that shows and lasts.

**To talk with the Overhead Door Distributor nearest you, call 1-800-929-DOOR.**

### Overhead Door Corporation

2501 S. State Hwy. 121 Bus., Suite 200

Lewisville, Texas 75067

1-800-929-DOOR

[www.OverheadDoor.com](http://www.OverheadDoor.com)



INDUSTRY LEADING  
COMMERCIAL & INDUSTRIAL SOLUTIONS

The Overhead Door Corporation family of quality commercial and industrial products includes:



A part of Sanwa Holdings Corporation